

Power Systems & Controls

Series EPM-Extended Power Module



The Series EPM is a stand alone power module designed to replace or supplement batteries in UPS systems. It is an energy storage system that creates power by means of kinetic energy conversion rather than the chemical reaction process utilized by existing battery strings. PS&C's Flywheel topology is an extremely reliable source of

emergency power designed to support the DC voltage long enough for the standby engine -

generator to start and be transferred on line, even after the engine generator has been in service for a few years.

The flywheel is driven by an induction motor through a (VFD) variable frequency drive. The DC output is derived from a three phase synchronous output converted via a rectifier. As the standard construction is a two bearing, single shaft machine. There are few serviceable components in the unit, making maintenance requirements minor. PS&C's Series EPM combines the latest engineering methods with "Brute Force". The EPM offers the durability and rigidity of a battery without the maintenance required or trouble associated with them.

Standard Features and Equipment

- High efficiency induction motor
- Brushless synchronous generator
- Precision control variable frequency drive with constant speed operating mode @ unit power factor
- Performance will not decline over time
- Six pulse three phase rectifier
- Anti-Friction bearings throughout
- Winding over-temperature protection
- Over-speed protection
- Front and Left side access only
 - Full M-G access (Front only)
- Harmonic input filter
- Output dry contacts for remote status
- No cabinet ventilation fans utilized
- Not susceptible to ground noise
- No environmental control required
 - Air conditioning
 - Heating
- EPM utilizes PS&C's "Quiet Packaging" method of sound attenuation
- 2 Axis vibration sensors
- No nuisance engine starts
- Remote Engine generator start circuit
- Output voltage adjustment
- Touch screen control and metering
 - Over 250 events storage capability

Optional Features

- Modem & Serial port
- Remote communications
- Remote monitor (Status & Alarm)
- Remote touch screen (Control)
- Parallel modules
- Custom building management interface module
- NEMA 3R enclosure
- Additional sound attenuation
- Color touch screen

SYSTEM SPECIFICATIONS

*Note: System performance shown is typical and is dependent upon M-G sizing, options desired, and loading of the system. Specific performance levels can be achieved through custom modifications and sizing of components.

INPUT		OUTPUT	
Voltage		Voltage	
Nominal Available		Nominal Available	
@ 60 Hz	208, 220, 480	Time and Power	
@ 50 Hz	220, 380	Standard Nominal Available	
		See Chart	
Phase	3 phase 3 wire plus ground	Phase	2 Phase Wire plus ground
Recharge Time	20 minutes max	ENVIRONMENT	
Start Time	30 minutes max	Storage Temperature:	0° to 120° F
Frequency Tolerance		OP Temperature:	0° to 120° F
Magnitude Tolerance		Altitude:	0 to 3300 meters (0 to 5,000 feet)
		Humidity:	0 to 95% non-condensing
		Noise Level:	73dBa at 1.5 meters (five feet)
Continuous:	+10%, -20%		
Transient:	1500V for 10 ms		
Power Factor	0.9 lagging at full load		
Starting Inrush	Less than 100% of Rating		

DIMENSIONS (Inches)					RUN TIME (Seconds)							
Model #	W	L	W	H	25kw	50kw	75kw	100kw	125kw	150kw	175kw	200kw
M-1	4100	48	48	76	108	60	36	27	22	20	17	15
M-2	4700	48	48	76	135	68	50	34	27	25	21	19
M-3	5600	48	48	76	180	90	60	50	20	33	29	25

Available through 2,000 kW
For sizes greater than 200 kW, consult factory

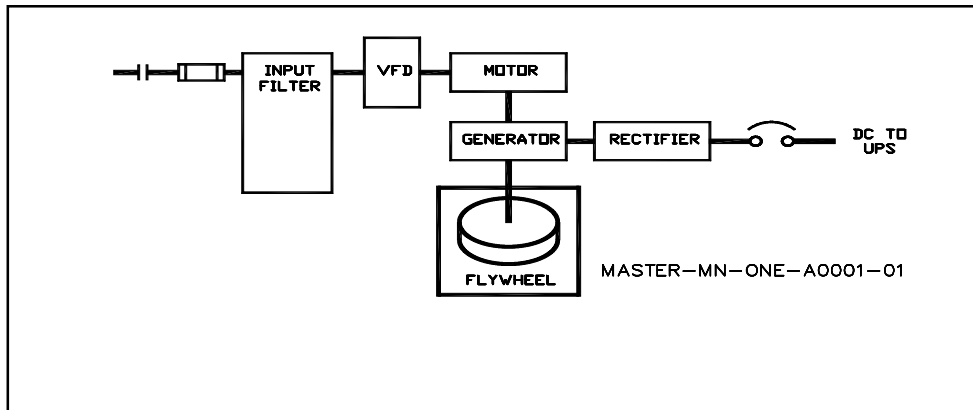

Series EPM One Line Diagram

Power Systems & Controls reserves the right to improve, enhance and modify the features and specifications of its products and services without prior notification.

POWER SYSTEMS
& CONTROLS
THE POWER IS ON!